

MODEL NUMBER:

□ 9035888 5" Shower Arm Extension

Includes:

- 5" Arm Extension

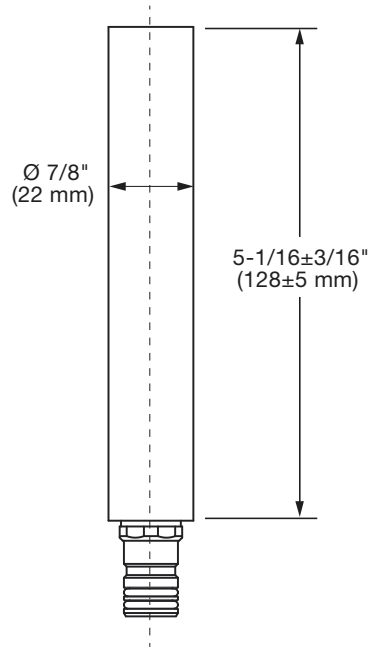

GENERAL DESCRIPTION:

Includes shower system 5" m extension. Use to extend shower arm for Right Angle shower systems.

Product Number	Description	Finish	
		Polished Chrome	Brushed Nickel
		002	295
9035888	Spectra Versa™ 5" Shower Arm Extension		