

# JASON<sup>®</sup>

HYDROTHERAPY

8328 MacArthur Dr. • North Little Rock, AR 72118  
 501.771.4477 • Fax: 501.771.2333  
 Customer Service: 800.255.5766  
 www.jasoninternational.com

## Designer Collection Specifications

# KT553

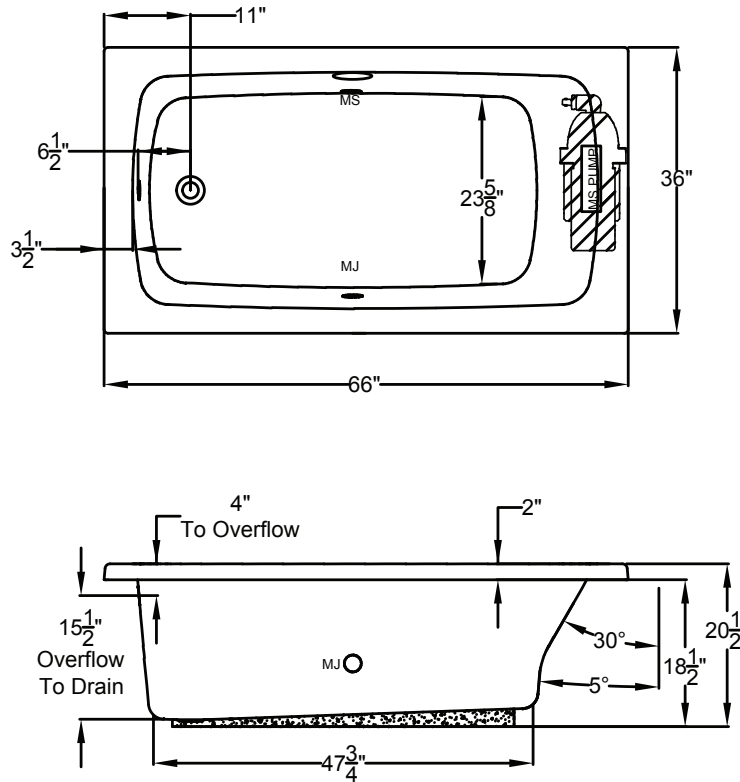

### MicroSilk<sup>®</sup>



Patents received or pending.

Note: Dimensional Tolerances: ±1/4"

<b>Drop-in-Hole Size:</b>	34" x 64"
<b>Operating Capacity:</b>	48 Gal.
<b>Overflow Capacity:</b>	75 Gal.
<b>Floor Loading / sq.ft.:</b>	49.5 lbs.
<b>Carton Weight:</b>	104 lbs.
<b>Cube:</b>	34.3 ft. <sup>3</sup>

<b>Standard</b>		A 120V system that includes a MicroSilk <sup>®</sup> unit, an electronic control, and a 20-minute timer.
<b>Premier</b>		A 120V system that includes a MicroSilk <sup>®</sup> unit; (2) Chromatherapy mood lights; Automatic Ozone System; an electronic control; and a 20-minute timer.
<b>Signature</b>		A 120V system that includes a MicroSilk <sup>®</sup> unit; (2) Chromatherapy mood lights; Automatic Ozone System, a digital control with LCD display; low water level and temperature sensors; enhanced user control options, a 20-minute timer; and Bluetooth Sound Immersion System. Control keypad controls the MicroSilk <sup>®</sup> unit, LED Chromatherapy mood lights, and shows equipment status, water temperature, and time remaining.

**Construction:** Fiberglass reinforced acrylic bath with Level Form<sup>™</sup> full-support base.

*We provide products listed with Intertek ETL SEMKO (Edison Testing Laboratories) U.S. and Canadian and with International Association of Plumbing and Mechanical Officials (IAPMO). Consult factory with your listing requirements.*