

### Features and Specifications:

- Bar/prep sink
- Outside dimensions: 16-1/4" x 18-1/4" x 9"
- Manufactured from 18 gauge, Type 304 stainless steel
- Underside affixed with multiple aluminum coated, high density rubber pads for sound absorption
- 1-1/4" x 3/4" machined, resin matrix rim
- 20mm radius corners
- Waste opening: 3-1/2"
- Sink surface has a soft satin brushed finish
- Can only be installed in new countertops, not existing countertops with existing sink cutout
- Undermount installation required. May not be top mounted
- This sink may be seamlessly installed in solid surface and laminate countertops
- This sink may be undermounted to all stone countertops. 1/16" to 1/8" overhang recommended
- Supplied without mounting adhesive, clips or template
- Digital templates for CNC machines are available at [www.karran.com](http://www.karran.com)
- Strainer basket shown not included with sink
- Optional bottom grid available

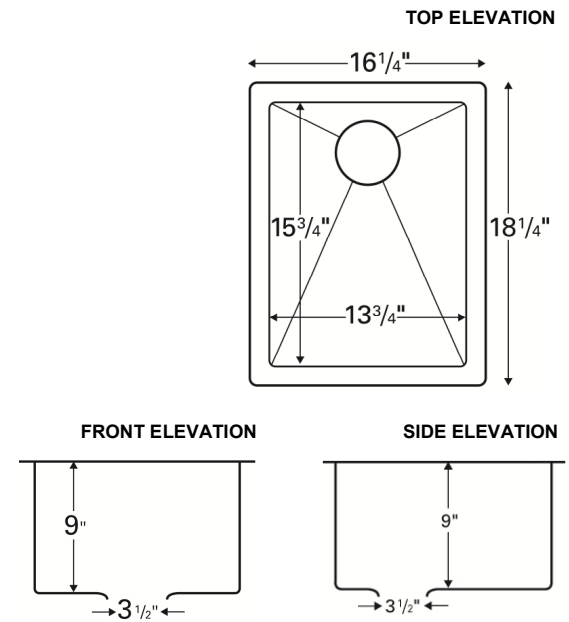

ALL DIMENSIONS ACCURATE TO 1/4"

Edge Series Sink Installed in Laminate



Edge Series Sink Installed in Solid Surface



### Certifications:



Recommended edge profiles in solid surface

