

## Features and Specifications:

- Vanity sink
- Outside dimensions: 21-7/8" x 15-3/4" x 6-1/4"
- Manufactured from an ultra high density, 100% pure acrylic resin
- Manufactured by thermoforming using heat and vacuum
- Underside reinforced with an FRP backing
- 1-1/4" x 3/4" machined resin matrix rim
- Heat, scratch and chip resistant
- Stain and thermal shock proof
- Completely non-porous
- Can only be installed in new countertops, not existing countertops with existing sink cutout
- Undermount installation required. May not be top mounted
- This sink may be seamlessly installed in solid surface and laminate countertops
- This sink may be undermounted to all stone products. 1/8" overhang recommended
- Available colors: Bisque and White
- Supplied without mounting adhesive, clips or template
- Digital templates for CNC machines available at [www.karran.com](http://www.karran.com)
- Strainer basket shown not included with sink

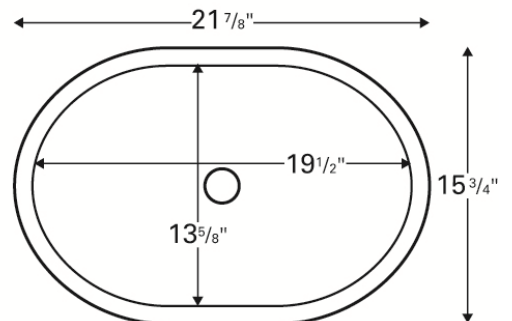

TOP ELEVATION



FRONT ELEVATION

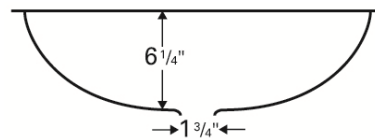

SIDE ELEVATION

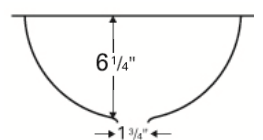

ALL DIMENSIONS ACCURATE TO 1/4"

Acrylic Series Sink Installed in Laminate



Acrylic Series Sink Installed in Solid Surface



## Certifications:

