



M•POWER™
1-1/2" AC Powered Sensor
Exposed Style Closet Flush Valve

Models: 8310AC16, 8310ACDF16,
 8311AC12



PRODUCT DESCRIPTION

- Sensor activated exposed water closet flushometer with brass angle stop valve
- Brass construction with chrome plated finish
- Chloramine resistant seals
- 1" IPS inlet supply
- 1-1/2" top spud
- High back pressure vacuum breaker
- Intended for use with floor mounted or wall hung top spud bowls with matching flow rates as specified by the fixture manufacturer

OPERATION

- Self-cleaning Accuset™ piston flush technology
- Mechanical override
- Adjustable infrared sensor range from 17" to 36"
- Optional 24 hour Sentinel Flush (factory setting is off)
- Operating Pressure Range: 20-125psi
- Compatible with 104630 transformer, powers up to 8 flush valves
- Vandal resistant angle stop and double o-ring connections

FLOW RATE

- 8310AC16 (1.6gpf/6.0Lpf)
- 8310ACDF16 (1.0/1.6gpf 3.8/6.0Lpf) – 1.0gpf up to 60 seconds/1.6gpf after 60 seconds
- 8311AC12 (1.28gpf/4.8Lpf) – WaterSense® certified

STOP VALVE

- All metal 1" IPS vandal resistant angle stop with double o-ring connection
- Adjustable installation (left or right connection)

STANDARDS

- Third party certified by IAPMO and CSA to meet ASME A112.19.2M and all applicable requirements referenced therein and complies with requirements of ASSE 1037
- BAA
- ADA 

WARRANTY

- Warranted for 5 years against material or manufacturing defects

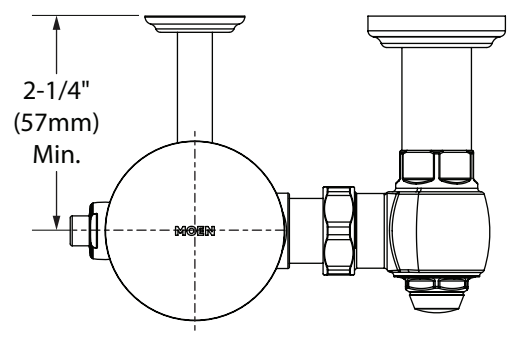
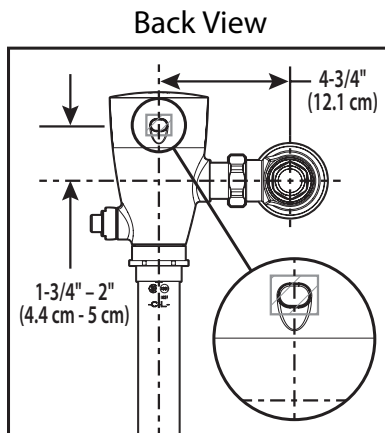
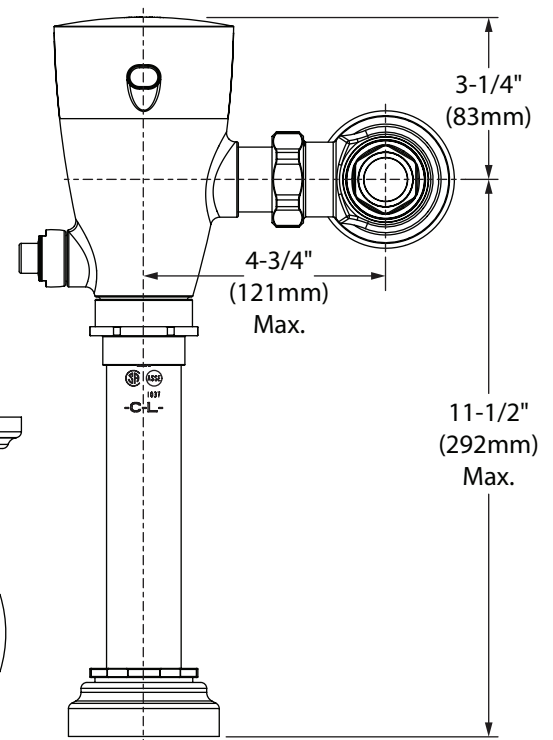

CRITICAL DIMENSIONS

(DO NOT SCALE)

PRODUCT DESCRIPTION

- Brass construction w/chrome plated finish
- 1" IPS supply
- 1-1/2" top spud
- 6" cable tube
- 18 guage x 24" (+) (-) wire leads
- Optional power adapters
- Single AC transformer (12v) #104406
- Multi-unit AC transformer (power up to 8 units) #104401

OPERATION

- Adjustable sensor eyes
- Low consumption AC powered (12 Volt transformer required)
- Self-diagnostic electronics
- Piston flushing mechanism
- Self cleaning filter system

FLOW

- Operating pressures 10 to 125 psi
- 1.28 gpf (4.8 lpf)
- 24 hour sentinel flush
- Manual override button

VALVE

- 1" IPS angle stop (vandal resistant)
- Adjustable installation (left or right connection)

STANDARDS

- Third party certified by CSA to meet ASME A112.19.2M, ASSE 1037 and all applicable requirements referenced therein

ADA

WARRANTY

- Warranted for 5 years against material or manufacture defects.

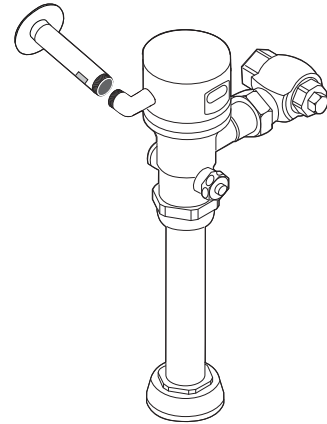

**1-1/2" AC Powered Exposed Style
Closet Flush Valve**

Model: 8311AC12

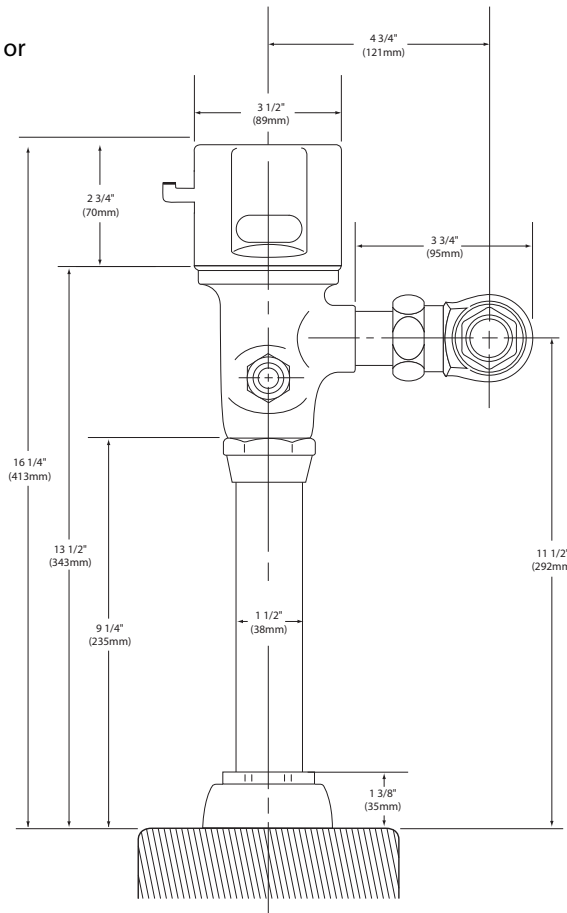

CRITICAL DIMENSIONS

(DO NOT SCALE)