

## PRODUCT DESCRIPTION

- Battery powered, sensor activated, exposed water closet flushometer retrofit
- Brass construction with chrome plated finish
- Chloramine resistant seals
- 1-½" tailpiece nut assembly
- Intended for use with bowls with matching flow rates as specified by the fixture manufacturer

## OPERATION

- Self-cleaning Accuset™ piston flush technology
- Mechanical override
- Adjustable infrared sensor range
- Four (4) Alkaline AA batteries included
- Battery life: Up to 8 years\*
- Low battery indicator light
- Optional 24 hour Sentinel Flush (Factory setting is off)
- Operating Pressure Range: 20-125psi

## FLOW RATE

### Closet

- 8310SR35 (3.5gpf/13.2Lpf)
- 8310R16 (1.6gpf/6.0Lpf)
- 8310RDF16 (1.0/1.6gpf 3.8/6.0Lpf) – 1.0gpf up to 60 seconds/1.6gpf after 60 seconds
- 8310SR128 (1.28gpf/4.8Lpf) – WaterSense® certified

### Urinal

- 8312R10 (1.0gpf/3.8Lpf)
- 8312SR05 (0.5gpf/1.9Lpf) – WaterSense® certified
- 8312SR125 (0.125 gpf/0.5Lpf) – WaterSense® certified

## STOP VALVE

- Adjustable installation (left or right connection)

## STANDARDS

- Third party certified by IAPMO and CSA to meet ASME A112.19.2M and all applicable requirements referenced therein and complies with requirements of ASSE 1037
- BAA
- ADA 

## WARRANTY

- Warranted for 5 years against material or manufacturing defects

\*Typical alkaline battery life at 130 uses per day is about 8 years



## M-POWER™ Battery Powered Sensor Exposed Style Retrofit Flush Valve

**Models:** 8310SR35, 8310R16,  
8310RDF16, 8310SR128, 8312R10,  
8312SR05, 8312SR125

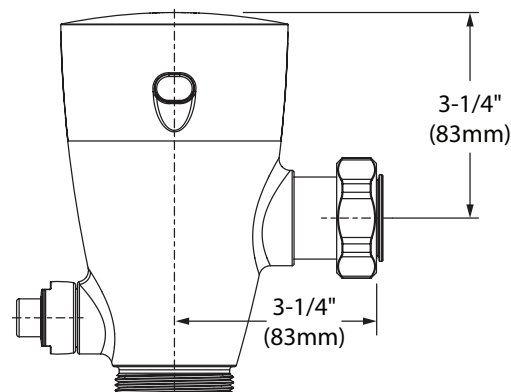
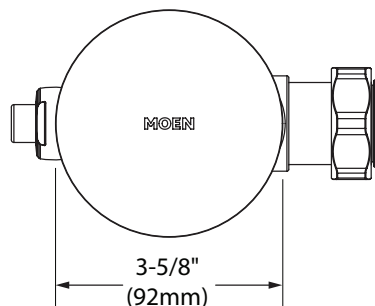

## CRITICAL DIMENSIONS

(DO NOT SCALE)

**PRODUCT DESCRIPTION**

- Brass construction w/chrome plated finish

**OPERATION**

- Adjustable sensor eyes
- Battery powered (4) standard AA (included)
- Average battery life 250,000 cycles
- Self-diagnostic electronics
- Piston flushing mechanism
- Self cleaning filter system
- Low battery indicator light

**FLOW**

- Operating pressures 10 to 125 psi
- 1.0 gpf (gallons per flush)
- 24 hour sentinel flush
- Manual override button

**STANDARDS**

- Third party certified by IAPMO and CSA to meet ASME A112.19.2M and all applicable requirements referenced therein and complies with requirements of ASSE 1037

- **ADA** 

**WARRANTY**

- Warranted for 5 years against material or manufacture defects.

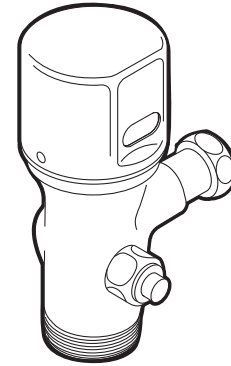

**Battery Powered Retro-Fit  
Urinal Flush Valve**

**Model: 8312R10**

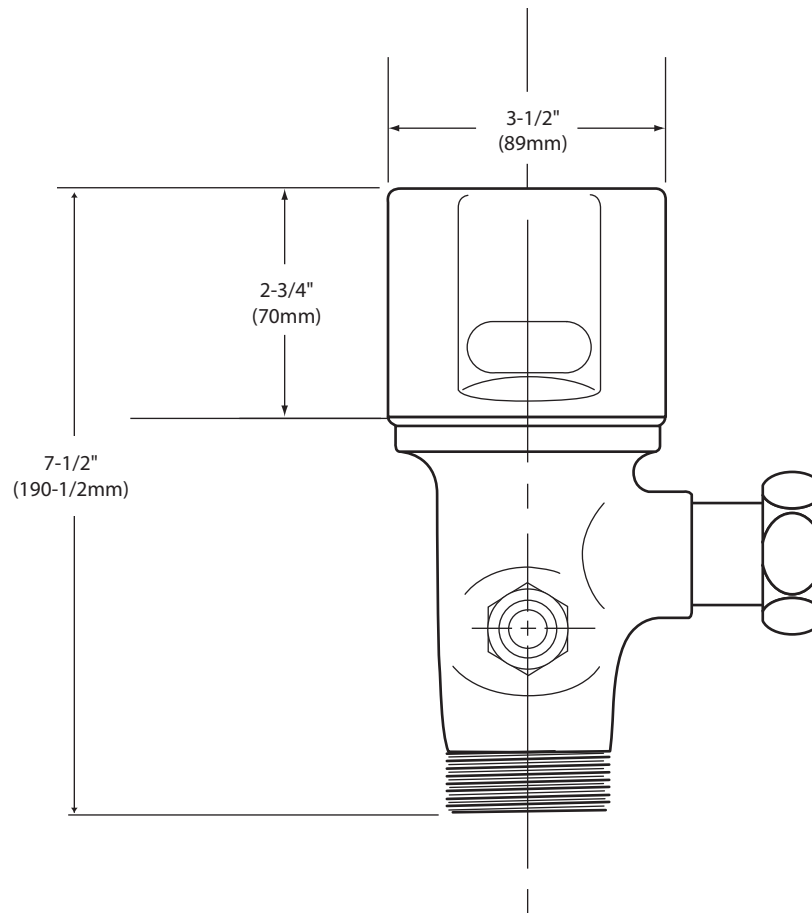

**CRITICAL DIMENSIONS**

(DO NOT SCALE)